

CDI

CHICAGO

OPERATING MANUAL FOR
LOGIC PLUS SERIES
ELECTRONIC INDICATORS

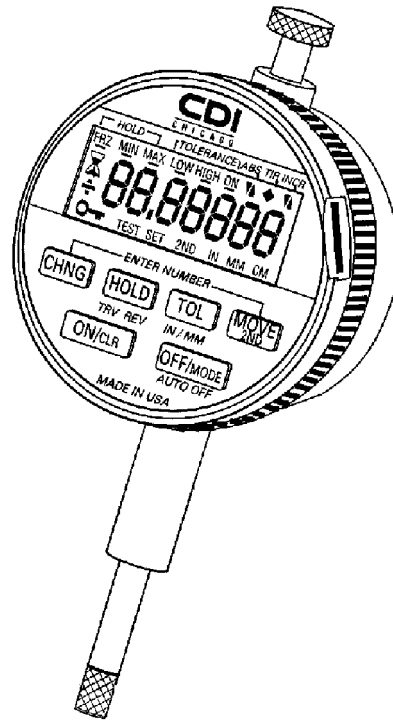

Choice of Three Power Sources

1. Batteries

A set of two Manganese Dioxide Lithium batteries will operate this electronic indicator for approximately 250 hours of normal usage. Because milliampere-hour ratings vary widely with manufacturers, normal usage time is very hard to predict. The lithium battery used in this indicator is an IEC standard, type CR2450. The indicators are shipped with the batteries not installed, and should not be installed until battery operation is desired.

NOTE: This indicator has an "AUTO-OFF" feature to conserve battery life. After 10 minutes of "no activity" (no key presses or spindle movement), the gage will turn itself off. This feature may be disabled if continuous operation is desired; see "AUTO-OFF On/Off" instructions in this book.

Installing Batteries

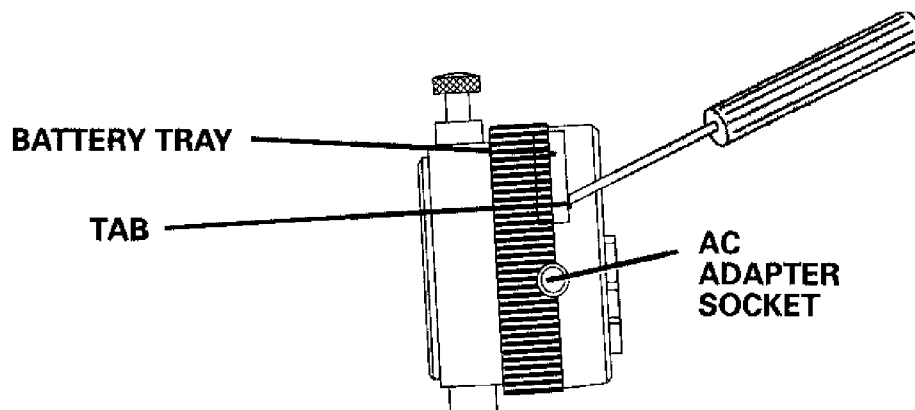

Using a narrow screwdriver, gently pry under the tab on the left side of plastic bezel and slide out the battery tray as you turn the indicator face side down.

Insert two batteries, "+" side up, into tray cavities, then slide the tray back into its bezel slot, taking care that the batteries stay in proper position.

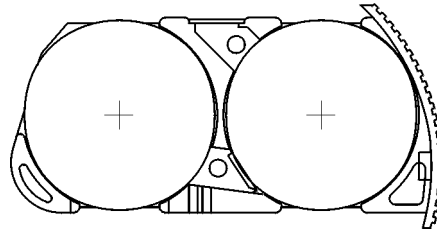

AC Adapter

AC adapters (providing 9VDC at 30ma. maximum to the indicator from a 115 or 230 VAC, 50/60 Hz line source) may be purchased from CDI. Although other 9V AC adapters with a 3/32" (2.5mm) mini-plug (center +) may be used, CDI adapters are recommended because they include current limiting to prevent damage from line fluctuations.

For 115 V (USA) operation - Order CDI Part #G11-0012

For 230 V (Europe) operation - Order CDI Part #G11-0014

First insert the mini-plug into the socket on the lower left side of the bezel (see drawing on page 2), then plug the adapter into a wall outlet. After turning the indicator "ON", disable the "AUTO-OFF" feature; see "AUTO OFF On/Off" on page 9.

2. Data I/O Connector

Power also may be provided through the data I/O connector, for special fixturing or applications where the indicator is integrated with another piece of equipment. A ripple-free 5 VDC (4.9 to 5.7 V) regulated voltage source is required. CDI Cable #G13-0034 or a custom variation of another CDI data cable must be used. Contact CDI for full information.

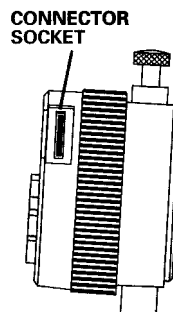

Button Functions

NOTE: Most functions are active on release of button(s).

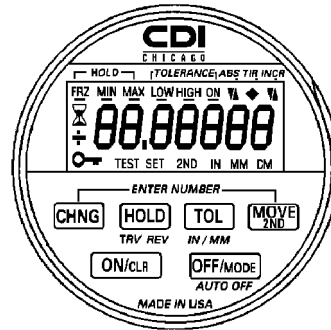

Key Function Controlled

OFF/MODE – Press & Release: Turns indicator off

- Press & Hold: Selects measuring mode - **INCR**, **TIR** or **ABS** – in rotating sequences. Release key when prompt indicates desired mode.

ON/CLR - Press & Release: Turns indicator on, or clears/resets indicator.

With **HOLD** off: Clears display to "0" (or to ABS number, if in ABS mode.)

With **MAX** or **MIN** with **HOLD** on: **Clears** display to spindle position*, leaves **HOLD** on.

With **FRZ** (Freeze) with **HOLD** on:
In **INCR** or **ABS** mode, clears to spindle position*, turns HOLD off.

In **TIR** mode (defaults to **FRZ**), clears to "0" and turns HOLD off.

*Or spindle position absolute number, if in **ABS**.

Press & Hold (For longer than 5 seconds): Enter/Exit display and key test mode.

TOL - Press & Release: Turns tolerance function on/off. (if **ERROR 3** appears, no tolerance numbers or an invalid tolerance number combination is stored in memory, i.e. either "0" or **LOW** number is higher than the **HIGH** number.)

Press & Hold: **ON**, **HIGH** and **LOW** are displayed in rotating sequence. Release key when cursor is under desired selection.

HOLD – Press & Release: Turns hold function on/off and cancels last selection.

Press & Hold: **MAX**, **MIN** and **FRZ** (Freeze) are displayed in rotating sequence. Release key when cursor is under desired selection.

MOVE/2ND – Press & Hold (for more than 2 seconds until **2ND** is displayed): Enables **2ND** and **3RD** functions such as **TR REV** (Travel Reverse), **IN/MM** and **AUTO OFF**.

Press & Release: Used with **CHNG** to activate set functions in **ABS**, **HIGH** and **LOW**.

CHNG - Used with **MOVE/2ND** key to activate set functions in **ABS**, **HIGH** and **LOW**.

Display-Operating Prompts & Conditions

Menu selection cursor under
HOLD or **TOLERANCE** areas.

AUTO-OFF is enabled to
conserve battery life.

Travel reversed; display counts
DOWN with inward movement for
INCR and **ABS**.

Negative reading. No
sign is displayed for
positive readings.

For **INCR** and **ABS**
measurement modes, display
counts **UP** with inward spindle
movement. This is normal
setting.

Features and preset numbers are
locked. Entering or changing of
presets or 2ND/3RD function
changes is prohibited.

For **TIR** measuring mode,
travel direction is ignored.

Indicator is in preset-number-
setting function for **ABS** or
TOLERANCE HIGH or **LOW**
preset numbers.

Displays **IN** for English
(inch), or **MM** for
Metric measure units.

Indicator ready for 2ND or
3RD function key entry
sequences.

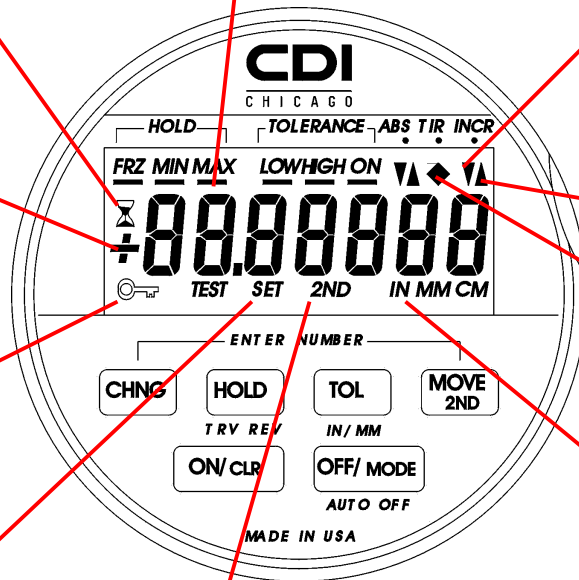

Measurement Modes

Three measuring modes are available with the LOGIC PLUS and remote display measuring systems:

1. **'INCR' - Incremental Measurement** - The displayed reading is the distance from a 'zero' reference, which may be the base of a precision test stand, etc. 'Zero' may be set at any point of spindle travel by pressing/releasing **"ON/CLR"** (with **'HOLD'** off).
2. **'TIR' - Total Indicator Readings** - The displayed reading is the difference between the highest and lowest spindle positions while moving the part under the spindle contact. This mode is most useful for checking roundness of shafts, surface flatness, etc. Special fixturing may be needed to hold both the indicator and the part. 'Zero' may be set at any point on the part by pressing/releasing **"ON/CLR"** (with **'HOLD'** off). The exact location of 'zero' is not important for accurate TIR measurements.
3. **'ABS' - Absolute or Preset Measurement** - The displayed reading is the distance from the 'preset' reference, which is set at any point of spindle travel by pressing/releasing **"ON/CLR"** (with **'HOLD'** off) while the spindle point is resting on a precision gage block or other reference standard. The 'ABS' (preset) number must match the dimension of the precision reference. See "To Set Absolute/Preset Numbers" on page 9.

NOTE: Accuracy of 'ABS' measurements is the ***sum of the accuracy's*** of the precision reference and the indicator. For example, if the indicator resolution/accuracy is ± 0.00005 " and the accuracy of the reference is ± 0.0001 ", the reliable measurement accuracy is ± 0.00015 ". Therefore, it is important to use the most accurate reference standard available.

Operating Instructions

To Enter

Absolute/Preset Measuring Mode

Press and hold "OFF/MODE" until cursor appears under 'ABS'

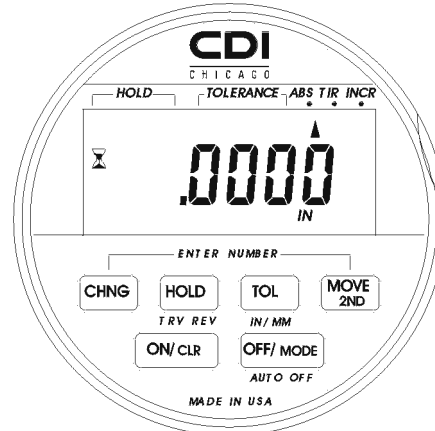

To Set

Absolute/Preset Numbers

NOTE: Be sure the cursor is under 'ABS'.

1. Press and release "CHNG" and "**MOVE/2ND**" simultaneously. NOTE: 'SET' appears at bottom of display.
2. Press and release "MOVE/2ND" until the sign or digit to be set is blinking.
3. Press and release "CHNG" to reverse the sign or increment the blinking digit.
4. Repeat steps 2 & 3 until desired # is entered.
5. Press and release "CHNG" and "**MOVE/2ND**" simultaneously to save number.

To Turn

AUTO OFF On/Off

- Press and hold "MOVE/2ND" until 2ND appears at bottom of display then release.
- Press and release "OFF/MODE" within 3 seconds.

NOTE: An hourglass appears at left side of display if 'AUTO OFF' is active.

TO

Clear Display ...

to zero or an Absolute/Present number:

- Press and release "ON/CLR".

To Verify

DATA I/O FORMAT

To view the current output format.

- Press and release "MOVE/2ND", until the 2ND appears in display, then "ON/CLR" and "MOVE/2ND" in sequence. Format information is displayed for about 3 seconds, then indicator automatically returns to normal operation. Format information is displayed as:

RS232 =rS232

MTI compatible =SEr

CDI mux BCD =Cdi

Bypass =bP

To Turn

FEATURE LOCK On/Off

Prevents inadvertent changing of functions, presets, etc.

1. Press and hold "MOVE/2ND" until 2ND appears at bottom of display, then release.
2. Press and release "ON/CLR" within 3 seconds.
3. Press and release "TOL" within 3 seconds - a key symbol will appear at the bottom left of display when features are locked.

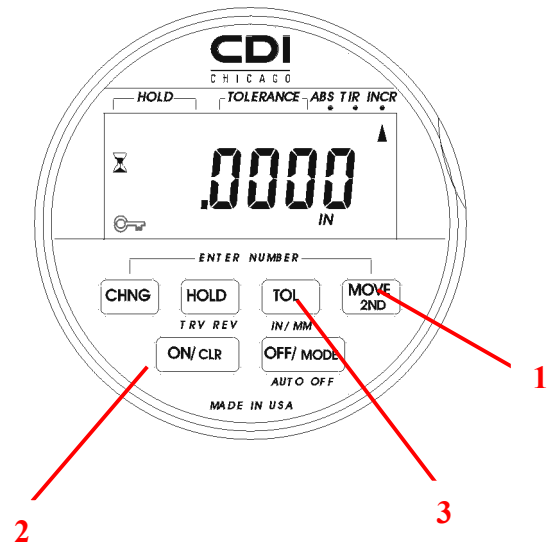

To Use

HOLD

To select type of HOLD - Freeze, Minimum or Maximum:

- Press and hold **"HOLD"** until cursor moves under desired type of hold; FRZ, MIN or MAX, then release.

To turn HOLD On/Off:

• Press and release **"HOLD"**

- MAX HOLD - Holds and displays highest reading.
- MIN HOLD - Holds and displays lowest reading.
- FREEZE HOLD - Freezes display when **"HOLD"** button is pressed.

NOTE: Pressing **CLR** button resets indicator to spindle position.

To Change

INCH/MILLIMETER

To change from one to the other:

- Press and hold **"MOVE/2ND"** until 2ND appears at bottom of display then release.

- Press and release **"TOL"** within 3 seconds.

NOTE: MM or IN will appear at bottom of display.

To Enter

Incremental Measuring Mode

- Press and hold **"OFF/MODE"** until cursor is under 'INCR'

To Turn

INDICATOR ON

Press **"ON/CLR"** and release when 'clr' appears on display

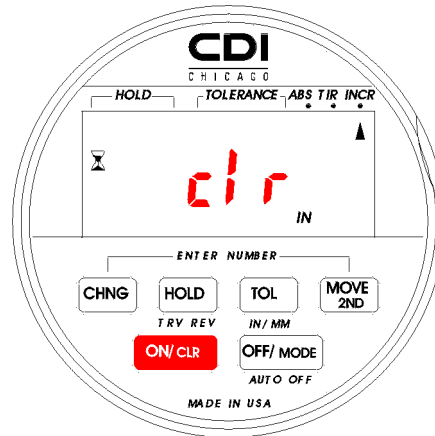

To Turn

INDICATOR OFF

- Press and release **"OFF/MODE"**

TO

Reset to DEFAULT

A total reset: clears all user settings and returns to factory-set defaults.

1. Press and hold **"MOVE/2ND"** until 2ND appears at bottom of display, then release.
2. Press and release **"ON/CLR"** within 3 seconds.
3. Press and release **"CHNG"** within 3 seconds.

NOTE: Cannot be done if Lock feature is on.

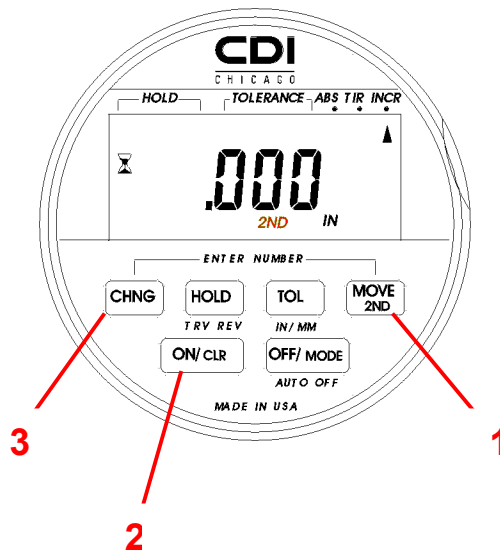

To Change

RESOLUTION

- Press and hold **"MOVE/2ND"** until 2ND appears at bottom of display then release.

- Press and release **"ON/CLR"** within 3 seconds.

- Press and release **"HOLD"** within 3 seconds.

Use **"CHNG"** key to step through available resolution selections:

1 = .00005" (.001mm)

2 = .0001" (.002mm)

3 = .00025" (.005mm)

4 = .0005" (.01mm)

5 = .001" (.02mm)

Press and release **"CHNG"** and **"MOVE/2ND"** simultaneously to save.

Note: Only resolutions coarser than indicator resolution-as-purchased are available.

To Enter

TEST MODE

Press and hold (for more than 5 seconds) **"ON/CLR"** to enter 'display and key' test mode.

To Exit

TEST MODE

Press and hold (for more than 5 seconds) **"ON/CLR"** to exit 'display and key' test mode.

To Enter

TIR Measuring Mode

Press and hold **"OFF/MODE"** until cursor on display is under 'TIR'.

To Set

TOLERANCE Numbers

- Press and hold **"TOL"** until cursor is under 'HIGH'.

- 1. Press and release **"CHNG"** and **"MOVE/2ND"** simultaneously. NOTE: 'SET' appears at bottom of display.
- 2. Press and release **"MOVE/2ND"** until the sign or digit to be set is blinking.
- 3. Press and release **"CHNG"** to reverse the sign or increment the blinking digit.
- 4. Repeat steps 2 & 3 until desired number is entered.
- 5. Press and release **"CHNG"** and **"MOVE/2ND"** simultaneously to save number

After step 5 is completed, the cursor will automatically move to 'LOW'.

- Repeat steps 1-5 to set 'LOW' tolerance.

Note: These steps 1-5 are the same as on page 9, under **Absolute/Preset Numbers** used to set a preset number.

To Turn

TOLERANCE On/Off

- Press and release **"TOL"**

To Change

TRAVEL DIRECTION

- Press and hold **"MOVE/2ND"** until 2ND appears at bottom of display then release.
- Press and release **"HOLD"** within 3 seconds.

Note: Arrow under ABS-TIR-INCR will show positive direction of spindle travel.

NOTE: Most functions are active on release of key(s).

Internal Memory

"LOGIC" Series indicators and remote displays include internal non-volatile memory to store all factory default and user settings. When the indicator is turned on, user settings and preset numbers will be the same as when the indicator was turned off.

NOTE: Many of the user settings are stored when the indicator is turned 'Off' by using the **"OFF/MODE"** key, or when the indicator turns itself off (AUTO OFF). However, if the indicator is turned off by removing power (by disconnecting the AC adapter or cutting power through the Data I/O connector), some or all of the user settings and/or changes may be lost!

Operating Precautions

1. Do not use the bottom of the spindle stroke as a base of measurement reference, as it is protected with a rubber shock absorber to prevent shock to the internal mechanism. The spindle should be offset .005"-.010" (.12 -.25 mm) from the bottom of travel.
2. Use of CDI type MS-10 or similar sturdy stands or fixtures for indicator mounting, where the base plate and indicator are mounted to a common post, is highly recommended for accurate and repeatable readings. The indicator must be mounted with the spindle perpendicular to the reference or base plate. If the indicator is stem-mounted, protect the indicator from attempted rotation, and from being stuck or bumped, to prevent stem/case mechanical alignment damage. Do not over-tighten the mounting mechanism, and use clamp mounting rather than set screws if at all possible, to prevent damage to the stem.
3. The bezel face can be rotated from its normal horizontal position for convenient viewing. Rotation is limited to 270 degrees and attempts to force it past its internal stop may damage the indicator.
4. Frequently clean the spindle to prevent sluggish or sticky movement. Dry wiping with a lint-free cloth usually will suffice, but isopropyl alcohol may be used to remove gummy deposits. Do not apply any type of lubricant to the spindle. Spindle dust caps and spindle boots are available for operation in dirty or abrasive environments.

1" Spindle dust cap - Order CDI Part #A21.0131

1" Spindle boot - Order CDI Part #CD170-1

Use a soft cloth dampened with a mild detergent to clean the bezel and front face of the indicator. Do not use aromatic solvents as they may cause damage.

5. Extremely high electrical transients - from nearby arc welders, SCR motor/lighting controls, radio transmitters, etc. - may cause malfunctions of the indicator's internal circuitry or 'ERROR 1' indications, even though the electronic design was created to minimize such problems. If at all possible, do not operate the indicator in plant areas subject to these transients. Turning the indicator 'OFF' for a few seconds, then back 'ON' from time-to-time may eliminate any problems. Also, use of an isolated AC line (for AC adapter operated indicators and AC powered remote displays), or an AC line filter - plus solid grounding of stands and fixtures - is recommended in these conditions.

Additional Display-Operating Prompts & Conditions

FLASHING DIGIT or +/- sign - Digit or sign affected by 'CHNG' key when setting or changing preset numbers.

FLASHING READING, with HIGH or LOW displayed Reading is out of tolerance, to the high or low side.

ERROR 1 - Spindle speed too fast, high electrical noise, etc.

ERROR 2 - Counter overflow, i.e. counter number (spindle + preset number) out of counter range.

ERROR 3 - Improper tolerance combination, i.e. both "HIGH" and "LOW" set to 'O' or same number, or "LOW" set to a higher number than "HIGH". Occurs only when 'TOL' is on.

ERROR 4 - Display overflow, i.e. number too large to be properly displayed. Moving spindle to acceptable range eliminates error message.

Data Output

'LOGIC' Series indicators and remote displays provide users with multiple data output formats. The cable attached to the indicator when it is turned on determines the output format in use. Cables for each format can be purchased from CDI. These cables also provide remote control of 'ON/CLR' and 'HOLD' functions, plus +5v regulated power input. For special applications, an ERROR FLAG output and/or custom cables also can be provided; contact CDI for information.

CAUTION: Use of cables other than those provided or approved by CDI can cause irreparable damage to the indicator or data output port, and such damage is not covered by the CDI Limited Warranty.

Standard RS232 Format - Communications protocol is 1200 baud, no parity, 8 data bits, 1 stop bit. RS232 can be read by any IBM PC-compatible computer, RS232 serial printer or other device, provided the device can be set to this protocol. A DB25 pin adapter may be necessary for non-standard devices. "WINDOWS" terminal and other communications software, "WEDGE" software, etc., may be used with this format.

Cables Required:

CDI #GO3-0018 - For IBM Compatible PC (CDI indicator to DB25F)

CDI #GO3-0021 - For CDI serial printer types G19-0001/G19- 0002 & G19-0003 (CDI indicator to DB25M)

MITUTOYO Compatible Format - Use with MITUTOYO compatible printers, collection devices, etc.

Cable Required:

CDI #G03-0019 - CDI indicator to MTI 10 pin

CDI (Multiplexed BCD) Format - Furnished with pigtails one end.

Cable Required:

CDI #GI3-0034 - Also may be used for remote control of 'ON/CLR' or 'HOLD' functions, or external power (+5V regulated) input. (CDI indicator to pigtail wires.)

BYPASS FORMAT - Permits indicator to be used as a probe for the CDI remote display: bypasses 'raw' unprocessed signals from the detector system directly to the data output connector. In this operation mode, power for the indicator is supplied by the remote display.

Cable Required:

CDI #GI3-0022 - CDI indicator to 6-pin DIN

IMPORTANT- Indicator and remote display *must* be of same base resolution. If the two (2) are different base resolutions, you will experience compatibility problems.

Limited Warranty

"PLUS SERIES" INDICATORS ARE WARRANTED FOR A PERIOD OF ONE YEAR AGAINST DEFECTIVE MATERIALS OR WORKMANSHIP. THIS WARRANTY DOES NOT APPLY TO PRODUCTS THAT ARE MISHANDLED, MISUSED, ETCHED, STAMPED, OR OTHERWISE MARKED OR DAMAGED, NOR DOES IT APPLY TO DAMAGE OR ERRONEOUS OPERATION CAUSED BY USER TAMPERING OR ATTEMPTS TO MODIFY THE INDICATOR. UNITS FOUND TO BE DEFECTIVE WITHIN THE WARRANTY PERIOD WILL BE REPAIRED OR REPLACED FREE OF CHARGE AT THE OPTION OF CDI. A NOMINAL CHARGE WILL BE MADE FOR NON-WARRANTY REPAIRS, PROVIDED THE UNIT IS NOT DAMAGED BEYOND REPAIR.



CHICAGO DIAL INDICATOR CO., INC.

1372 Redeker Road - Des Plaines, IL 60016

Telephone: 847/827-7186

FAX: 847/827-0478